

SPUR-BEVEL UNIT FOR MULTI-TURN VALVES 2CK-2.1

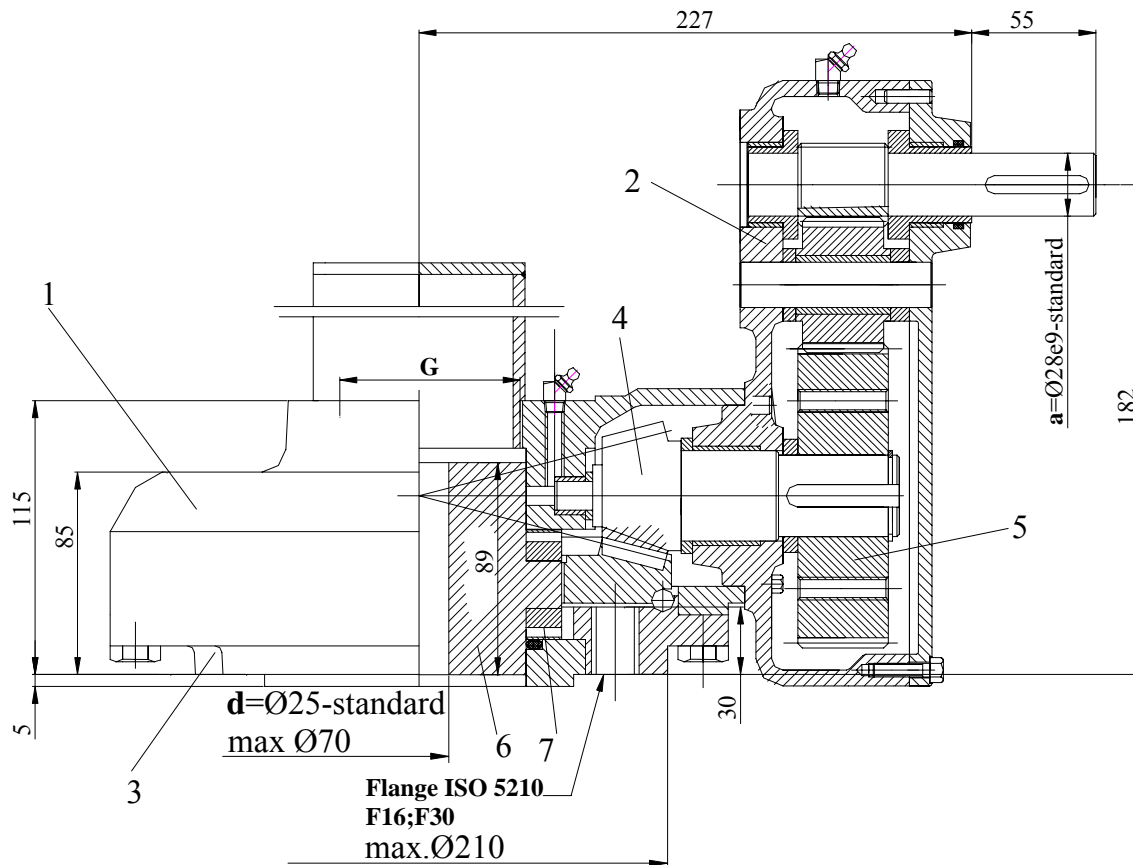

Sheet no.	554a
Date	14.09.2004



MATERIALS	
1.Bevel gear housing:	OT 450/GS 45
2.Cylindrical gear housing:	OT450/GS 45
3.Intermediate:	OT 450/GS 45
4.Bevel gear:	OLC 45/C45
5.Cylindrical gear:	OLC45/C45
6.Driving nut:	Cu Al10Fe 3T Fagn Ni 22
7.Bearing:	ANK 90120

TECHNICAL FEATURES	
● Bevel gear ratio:	9,55;14,4
● Output torque:	2000 Nm
● Axial load:	320 kN

Ratio	Input torque (Nm)	D (mm)	Handwheel Tangential force(N)
9,55	350	600	2x580
14,4	248	600	2x450

ORDERING CODE :

2CK 2.1 x 9,55 - F16 - OB - 28 - 3" - 4 / 25

Type	Ratio	Coupling flange ISO 5210	OB- Driving nut Bz -standard OF- Driving nut Fagn Ni 22	28	3"	4	25	d- Coupling shape dimension d-Coupling shape code-acc. to NCI-30	G-Stem tube thread
a-Input shaft diameter-key acc. to DIN 6885									

Handwheel	-	A800-standard A600
Stem tube	-	A88,9(3")
Should be ordered separately!		

SPUR-BEVEL UNIT FOR MULTI-TURN VALVES 2CK-3

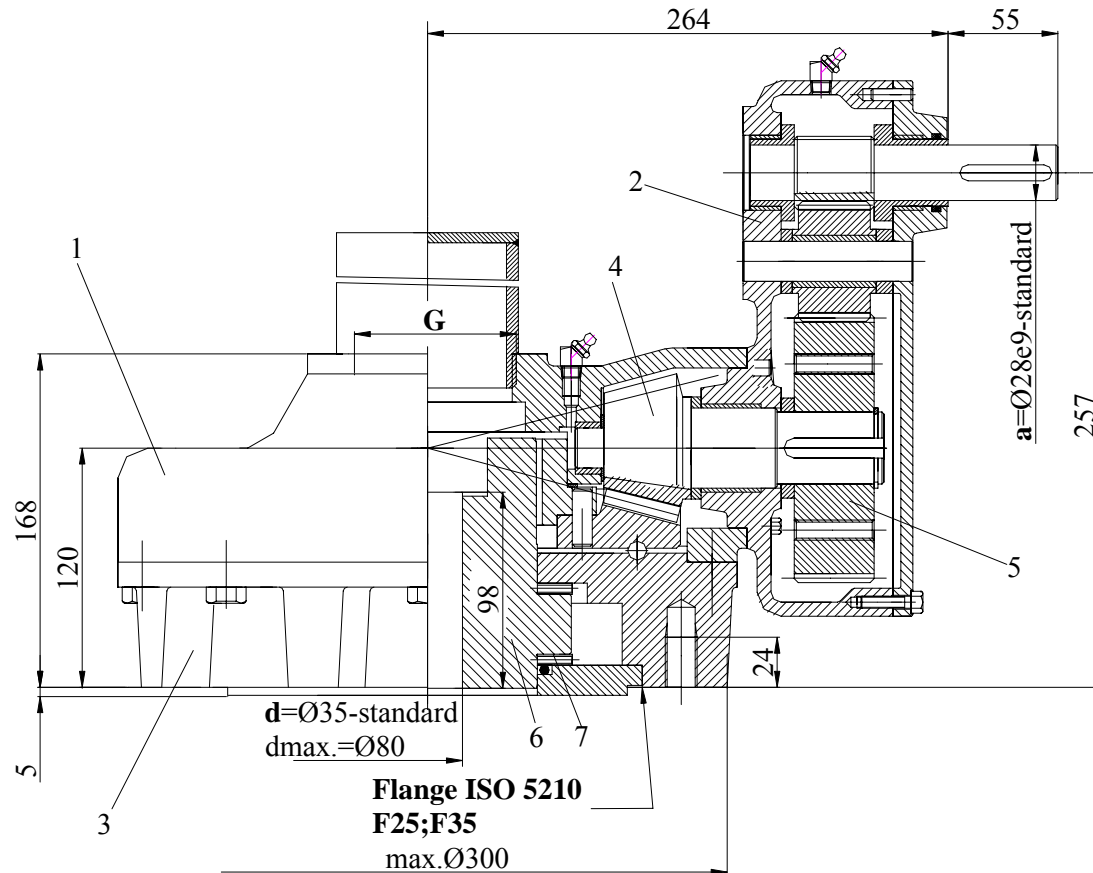

Sheet no.	553a
Date	21.10.2002

MATERIALS

1.Bevel gear housing:	OT 450/GS 45
2.Cylindrical gear housing:	OT450/GS 45
3.Intermediate:	OT 450/GS 45
4.Bevel gear:	OLC 45/C45
5.Cylindrical gear:	OLC45/C45
6.Driving nut:	Cu Al10Fe 3T
	Fagn Ni 22
7.Bearing:	AXK110145

TECHNICAL FEATURES

- Bevel gear ratio: 16
- Output torque: 3300 Nm
- Axial load: 380 kN

Ratio	Input torque (Nm)	D (mm)	Handwheel Tangential force(N)
16	327	600	2x545
	327	800	2x400

ORDERING CODE :

2CK 3 x 16 - F25 - OB - 28 - 3" - 4 / 35

Type	Ratio	Coupling flange ISO 5210	OB- Driving nut Bz -standard	OF- Driving nut Fagn Ni 22	d- Coupling shape dimension	d-Coupling shape code-acc. to NCI-30	G-Stem tube thread	a-Input shaft diameter-key acc. to DIN 6885
------	-------	--------------------------	------------------------------	----------------------------	-----------------------------	--------------------------------------	--------------------	---

Handwheel - A800-standard
A600
Stem tube - A88,9(3")
Should be ordered separately!

SPUR-BEVEL UNIT FOR MULTI-TURN VALVES 2CK-5



Sheet no.	555a
Date	14.09.2004

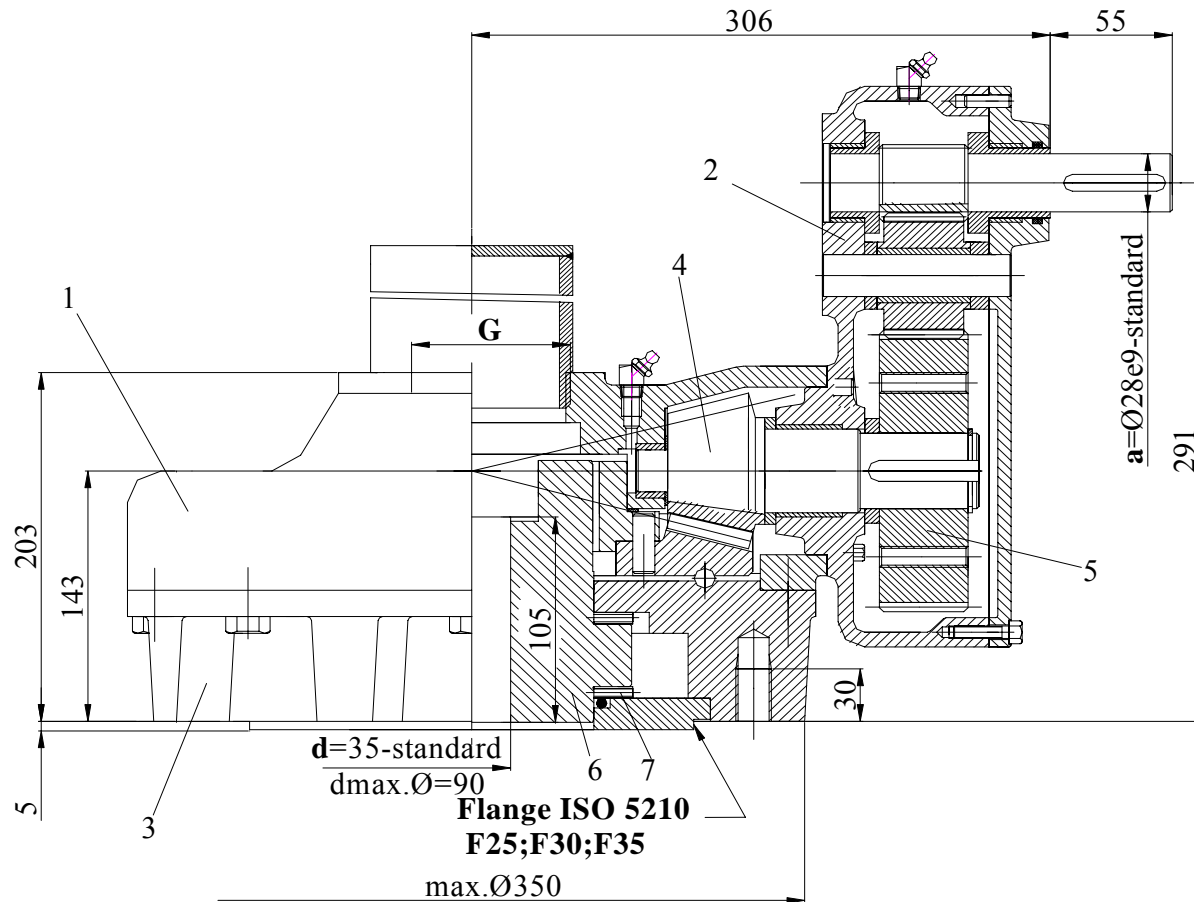

MATERIALS	
1.Bevel gear housing:	OT 450/GS 45
2.Cylindrical gear housing:	OT450/GS 45
3.Intermediate:	OT 450/GS 45
4.Bevel gear:	OLC 45/C45
5.Cylindrical gear:	OLC45/C45
6.Driving nut:	Cu Al10Fe 3T
	Fagn Ni 22
7.Bearing:	AXK120155

TECHNICAL FEATURES	
• Bevel gear ratio:	24;40
• Output torque:	5000 N m
• Axial load:	570 k N

Ratio	Input torque (N m)	D (mm)	Handwheel Tangential force(N)
24	340	600	2x570
40	205	600	2x345

ORDERING CODE :

2CK 5 x 24 - F30 - OB - 28 - 3 1/2" - 4 / 35

Type	Ratio	Coupling flange ISO 5210	OB- Driving nut Bz -standard OF- Driving nut Fagn Ni 22	28	3 1/2"	4	/	35	d- Coupling shape dimension d-Coupling shape code-acc. to NCI-30 G-Stem tube thread	a-Input shaft diameter-key acc. to DIN 6885
------	-------	--------------------------	--	----	--------	---	---	----	---	---

Handwheel	-	A800-standard A600
Stem tube	-	A102(3 1/2")-standard A115(4")
<i>Should be ordered separately!</i>		

SPUR-BEVEL UNIT FOR MULTI-TURN VALVES 2CK-8



Sheet no.	547a
Date	14.09.2004

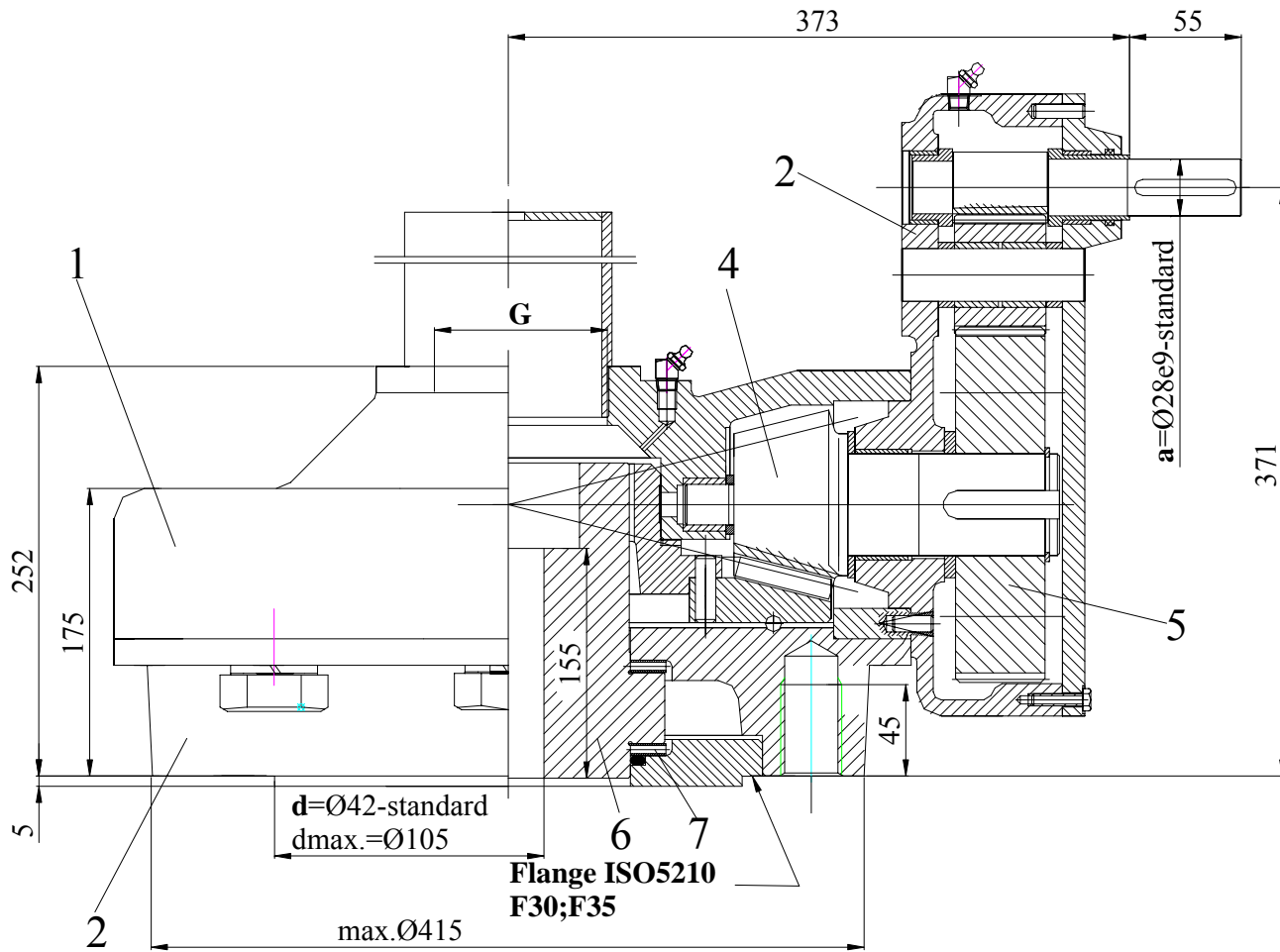

MATERIALS

1.Bevel gear housing:	OT 450/GS 45
2.Cylindrical gear housing:	OT450/GS 45
3.Intermediate:	OT 450/GS 45
4.Bevel gear:	OLC 45/C45
5.Cylindrical gear:	OLC45/C45
6.Driving nut:	Cu Al10Fe 3T
	Fagn Ni 22
7.Bearing:	AXK140180

TECHNICAL FEATURES

- Total gear ratio: 34,6;58
- Output torque: 8000 Nm
- Axial load: 800 kN

Ratio	Input torque (Nm)	D (mm)	Handwheel Tangential force(N)
34,6	385	800	2x480
58	230	800	2x290

ORDERING CODE :

2CK 8	x 34,6	- F35	- OB	- 28	- 5"	- 4 / 42
Type	Ratio	Coupling flange ISO 5210	OB- Driving nut Bz -standard OF- Driving nut Fagn Ni 22			d- Coupling shape dimension d-Coupling shape code-acc. to NCI-30 G-Stem tube thread a-Input shaft diameter-key acc. to DIN 6885

Handwheel - A800-standard
A600
Stem tube - A141,3(5")
Should be ordered separately!

SPUR-BEVEL UNIT FOR MULTI-TURN VALVES 2CK-10



Sheet nr.	557a
Date	14.09.2004

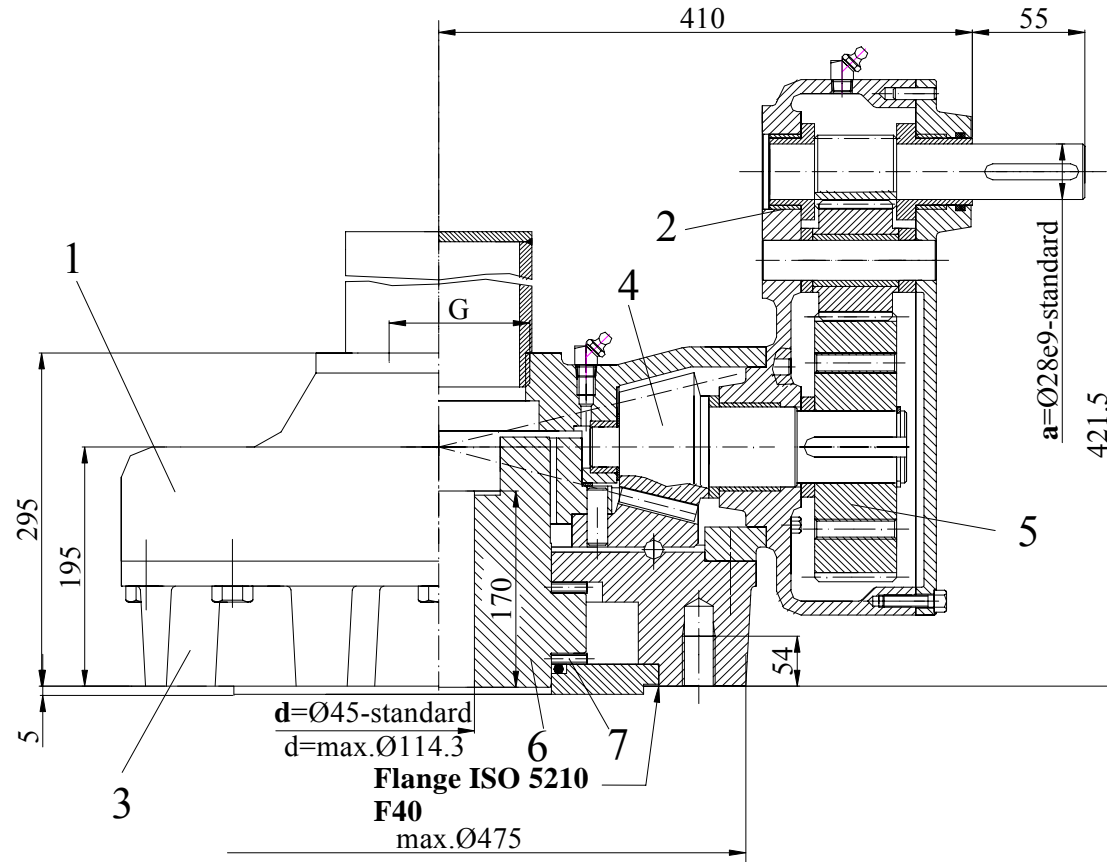

MATERIALS

- 1.Bevel gear housing: OT 450/GS 45
- 2.Cylindrical gear housing:OT450/GS 45
- 3.Intermediate: OT 450/GS 45
- 4.Bevel gear: OLC 45/C45
- 5.Cylindrical gear: OLC45/C45
- 6.Driving nut: Cu Al10Fe 3T
Fagn Ni 22
- 7.Bearing: AXK150190

TECHNICAL FEATURES

- Bevel gear ratio: 47.4;80,5
- Output torque: 10000 Nm
- Axial load: 950 kN

Ratio	Input torque (N m)	D (mm)	Handwheel Tangential force(N)
47.4	332	800	2x415
80,5	210	800	2x350

ORDERING CODE :

2CK 10 x 47,4 - F40 - OB - 28 - 5 1/2" - 4 / 45

Type	Ratio	Coupling flange ISO 5210	OB- Driving nut Bz -standard OF- Driving nut Fagn Ni 22	28	5 1/2"	4	d- Coupling shape dimension d-Coupling shape code-acc. to NCI-30 G-Stem tube thread	45
							a-Input shaft diameter-key acc. to DIN 6885	

Handwheel - A800-standard
A600
Stem tube - A150(5 1/2")
Should be ordered separately!

SPUR-BEVEL UNIT FOR MULTI-TURN VALVES 2CK-12



Sheet no.	558b
Date	01.09.2006

MATERIALS

- 1. Bevel gear housing: OT 450/GS 45
- 2. Cylindrical gear housing: OT450/GS 45
- 3. Intermediate: OT 450/GS 45
- 4. Bevel gear: OLC 45/C45
- 5. Cylindrical gear: OLC45/C45
- 6. Driving nut: Cu Al10Fe 3T
Fagn Ni 22
- 7. Bearing: AXK150190; AXK160200

TECHNICAL FEATURES

- Bevel gear ratio: 47.4; 80,5
- Output torque: 12000 Nm
- Axial load: 1250 kN

Ratio	Input torque (N m)	D (mm)	Handwheel Tangential force(N)
47.4	332	800	2x415
80,5	210	800	2x350

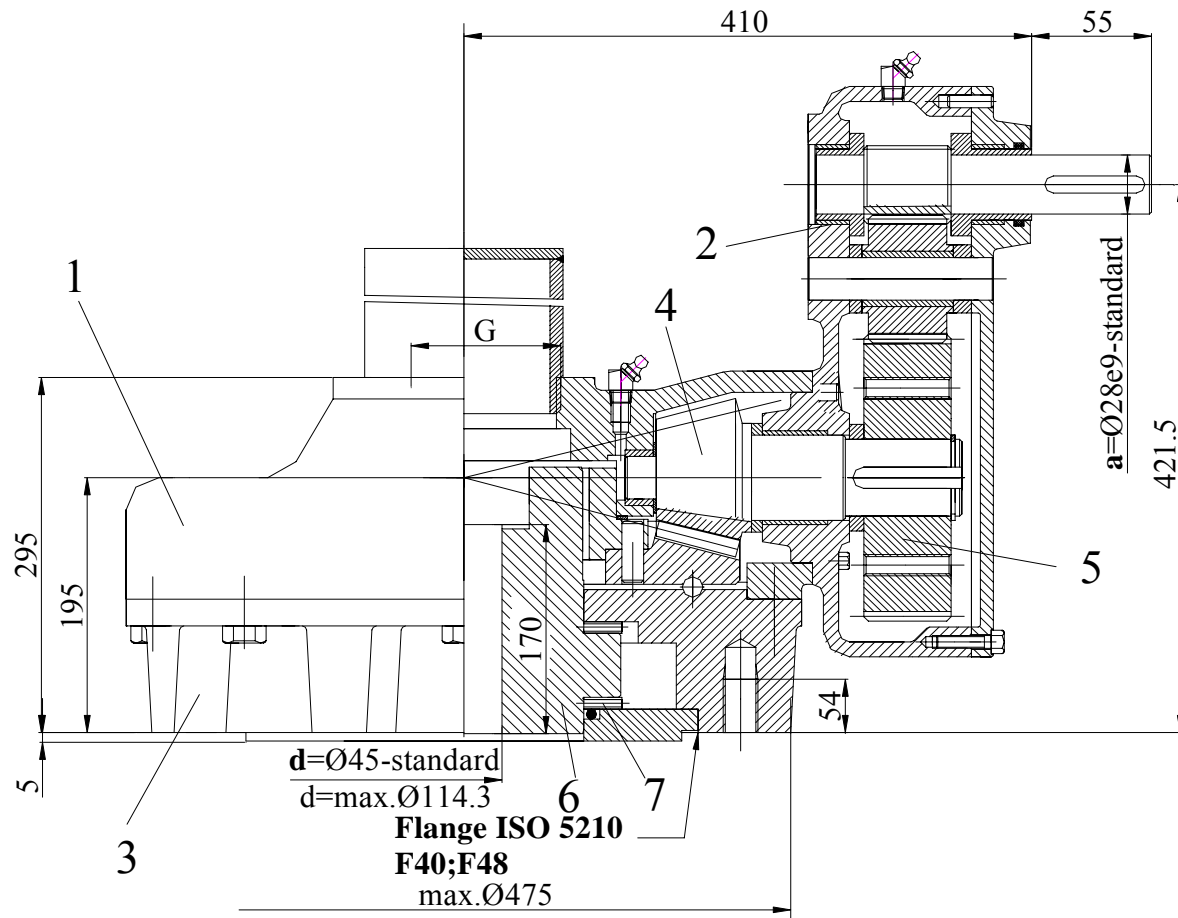

ORDERING CODE :

2CK 12 x 47,4 - F40 - OB - 28 - 5 1/2" - 4 / 45

Type	Ratio	Coupling flange ISO 5210	OB- Driving nut Bz -standard OF- Driving nut Fagn Ni 22	28	5 1/2"	4	45	d- Coupling shape dimension d-Coupling shape code-acc. to NCI-30 G-Stem tube thread a-Input shaft diameter-key acc. to DIN 6885
------	-------	--------------------------	--	----	--------	---	----	--

Handwheel - A800-standard
A600
Stem tube - A150(5 1/2")
Should be ordered separately!

SPUR-BEVEL UNIT FOR MULTI-TURN VALVES 2CK-15



Sheet no.	611b
Date	01.09.2006

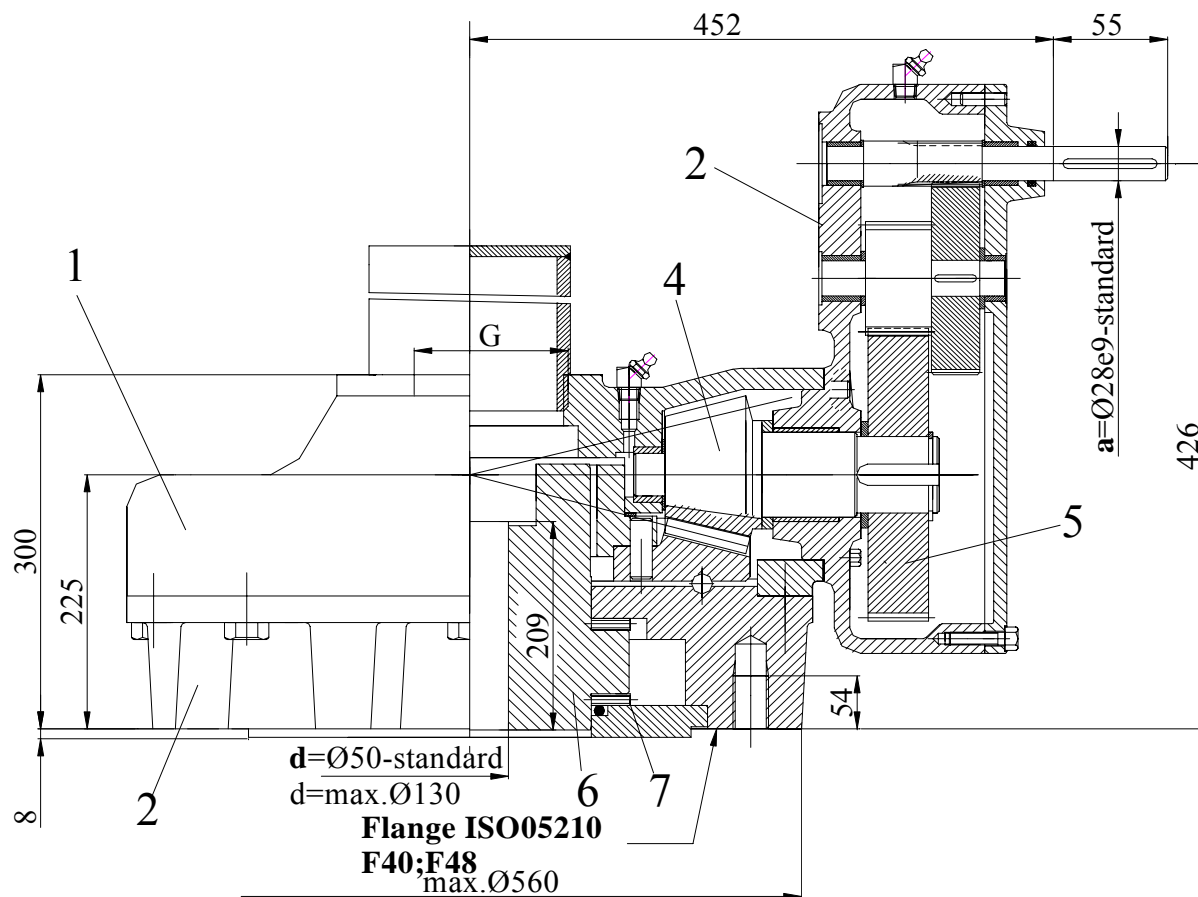

MATERIALS

1.Bevel gear housing:	OT 450/GS 45
2.Cylindrical gear housing:	OT450/GS 45
3.Intermediate:	OT 450/GS 45
4.Bevel gear:	OLC 45/C45
5.Cylindrical gear:	OLC45/C45
6.Driving nut:	Cu Al10Fe 3T
	Fagn Ni 22
7.Bearing:	AXK160200

TECHNICAL FEATURES

- Total ratio: 86,32;152,8
- Output torque: 15000 Nm
- Axial load: 1600 kN

Ratio	Input torque (Nm)	D (mm)	Handwheel Tangential force(N)
86,32	296	600	494
152,8	60	600	150

ORDERING CODE :

2CK 15 x 86,3 - F48 - OB - 28 - 6" - 4 / 50

Type	Ratio	Coupling flange ISO 5210	OB- Driving nut Bz -standard OF- Driving nut Fagn Ni 22	28	6"	4 / 50	d- Coupling shape dimension d-Coupling shape code-acc. to NCI-30 G-Stem tube thread a-Input shaft diameter-key acc. to DIN 6885
------	-------	--------------------------	--	----	----	--------	--

Handwheel	-	A800-standard A600
Stem tube	-	A170(6")
Should be ordered separately!		

SPUR-BEVEL UNIT FOR MULTI-TURN VALVES 2CK-18



Sheet no.	630b
Date	01.09.2006

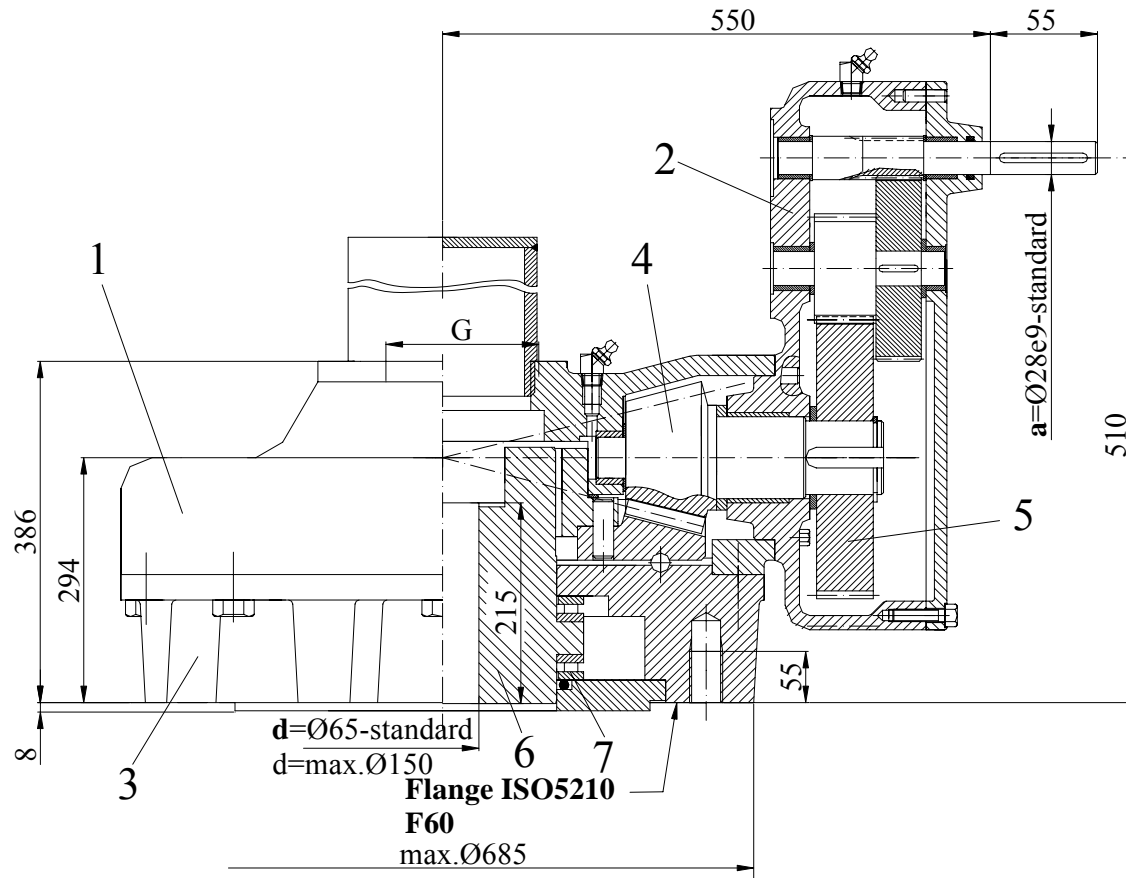

MATERIALS	
1. Bevel gear housing:	OT 450/GS 45
2. Cylindrical gear housing:	OT450/GS 45
3. Intermediate:	OT 450/GS 45
4. Bevel gear:	OLC 45/C45
5. Cylindrical gear:	OLC45/C45
6. Driving nut:	Cu Al10Fe 3T Fagn Ni 22
7. Bearing:	81144M

TECHNICAL FEATURES	
• Total ratio:	122,6;190
• Output torque:	22000 Nm
• Axial load:	1575 kN

Ratio	Input torque (Nm)	D (mm)	Handwheel tangential force(N)
122,6	435	800	2x592
190	210	800	2x265

ORDERING CODE :

2CK 18 x 122,6 - F60 - OB - 28 - 6" - 4 / 65

Type							d- Coupling shape dimension
Ratio							d-Coupling shape code-acc. to NCI-30
Coupling flange ISO 5210							G-Stem tube thread
OB- Driving nut Bz -standard							a-Input shaft diameter-key acc. to DIN 6885
OF- Driving nut Fagn Ni 22							

Handwheel	-	A800-standard
		A600
Stem tube	-	A170(6")
Should be ordered separately!		

SPUR-BEVEL UNIT FOR MULTI-TURN VALVES 2CK-32



Sheet no.	602b
Date	01.09.2006

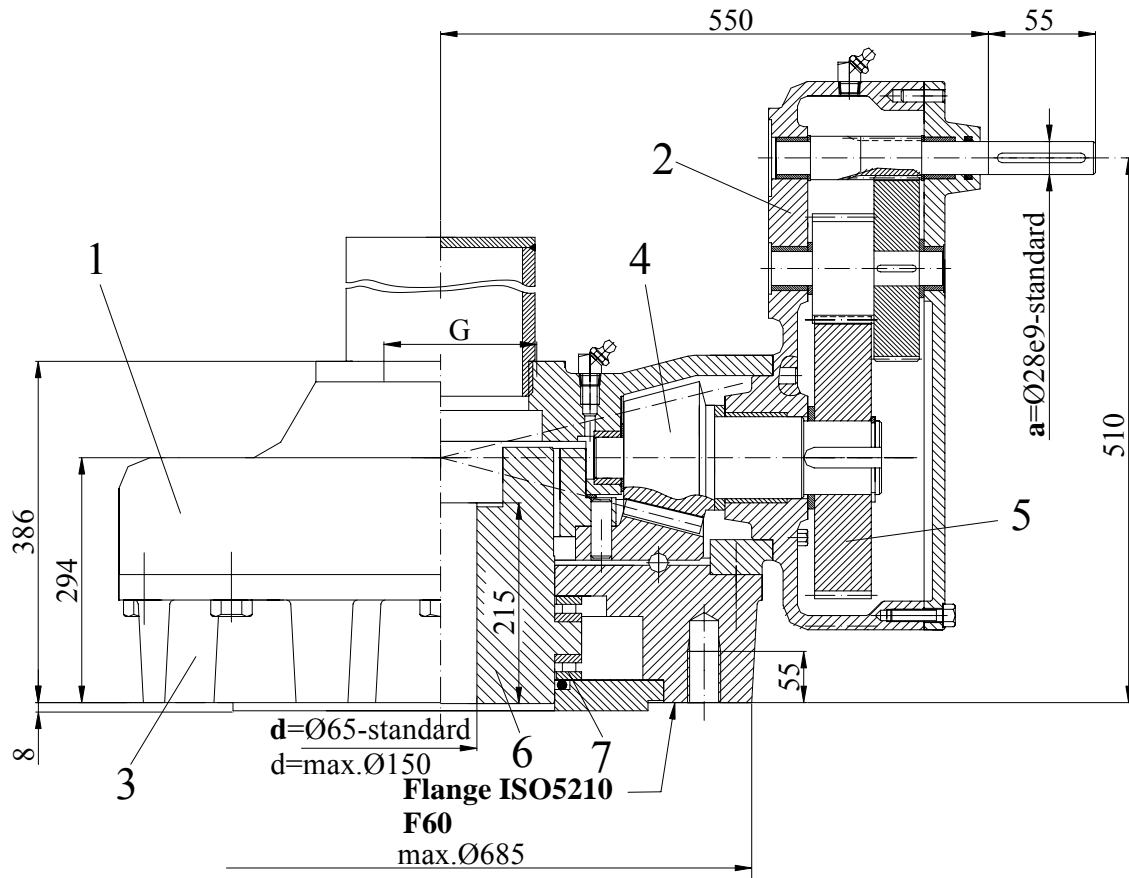

MATERIALS

1.Bevel gear housing:	OT 450/GS 45
2.Cylindrical gear housing:	OT450/GS 45
3.Intermediate:	OT 450/GS 45
4.Bevel gear:	OLC 45/C45
5.Cylindrical gear:	OLC45/C45
6.Driving nut:	Cu Al10Fe 3T Fagn Ni 22
7.Bearing:	81144M

TECHNICAL FEATURES

- Total ratio: 122,6;190
- Output torque: 32000 Nm
- Axial load: 1575 kN

Ratio	Input torque (Nm)	D (mm)	Handwheel tangential force(N)
122,6	435	800	2x592
190	210	800	2x265

ORDERING CODE :

2CK 32 x 122,6 - F60 - OB - 28 - 6" - 4 / 65

Type

Ratio

Coupling flange ISO 5210

OB- Driving nut Bz -standard

OF- Driving nut Fagn Ni 22

d- Coupling shape dimension

d-Coupling shape code-acc. to NCI-30

G-Stem tube thread

a-Input shaft diameter-key acc. to DIN 6885

Handwheel - A800-standard

A600

Stem tube - A170(6")

Should be ordered separately!

SPUR-BEVEL UNIT FOR MULTI-TURN VALVES 2CK-32RM

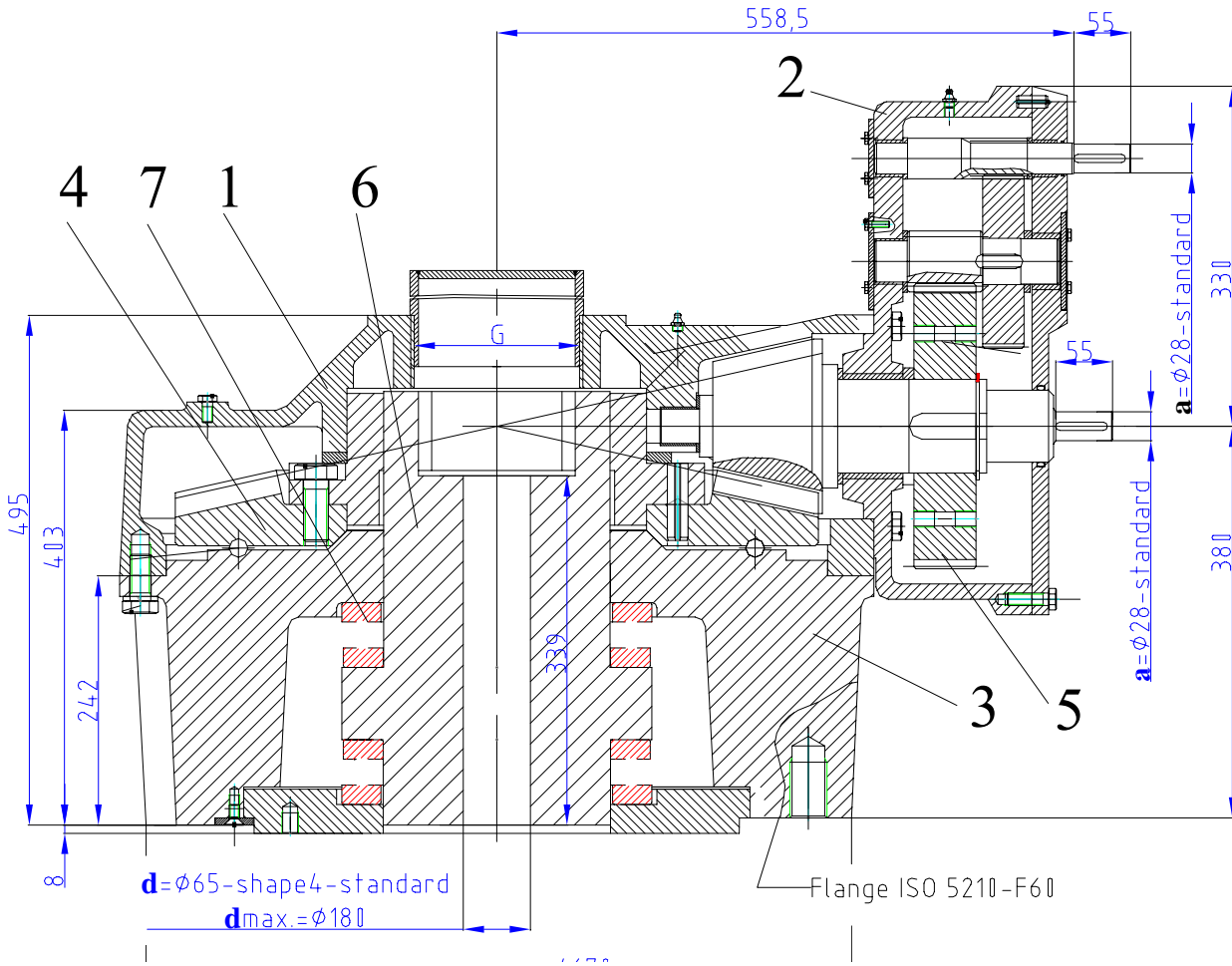

Sheet no.	907a
Date	01.09.2006

MATERIALS	
1. Bevel gear housing:	OT 450/GS 45
2. Cylindrical gear housing:	OT450/GS 45
3. Intermediate:	OT 450/GS 45
4. Bevel gear:	OLC 45/C45
5. Cylindrical gear:	OLC45/C45
6. Driving nut:	Cu Al10Fe 3T Fagn Ni 22
7. Bearing:	Φ220x Φ300x63 81244M

TECHNICAL FEATURES	
• Total ratio:	122,6
• Output torque:	40000 Nm
• Axial load:	2750 kN

Ratio	Input torque (Nm)	D (mm)	Handwheel tangential force(N)
122,6	543	800	2x592

ORDERING CODE :

2CK 32RM x 122,6 - F60 - OB - 28 - 6" - 4 / 65

Type									
Ratio									
Coupling flange ISO 5210									
OB- Driving nut Bz -standard									
OF- Driving nut Fagn Ni 22									

d- Coupling shape dimension
d-Coupling shape code-acc. to **NCI-30**

G-Stem tube thread

a-Input shaft diameter-**key** acc. to DIN 6885

Handwheel	-	A800-standard
		A600
Stem tube	-	A170(6")
<i>Should be ordered separately!</i>		

SPUR-BEVEL UNIT FOR MULTI-TURN VALVES 2CK-50



Sheet no.	920
Date	12.01.2005

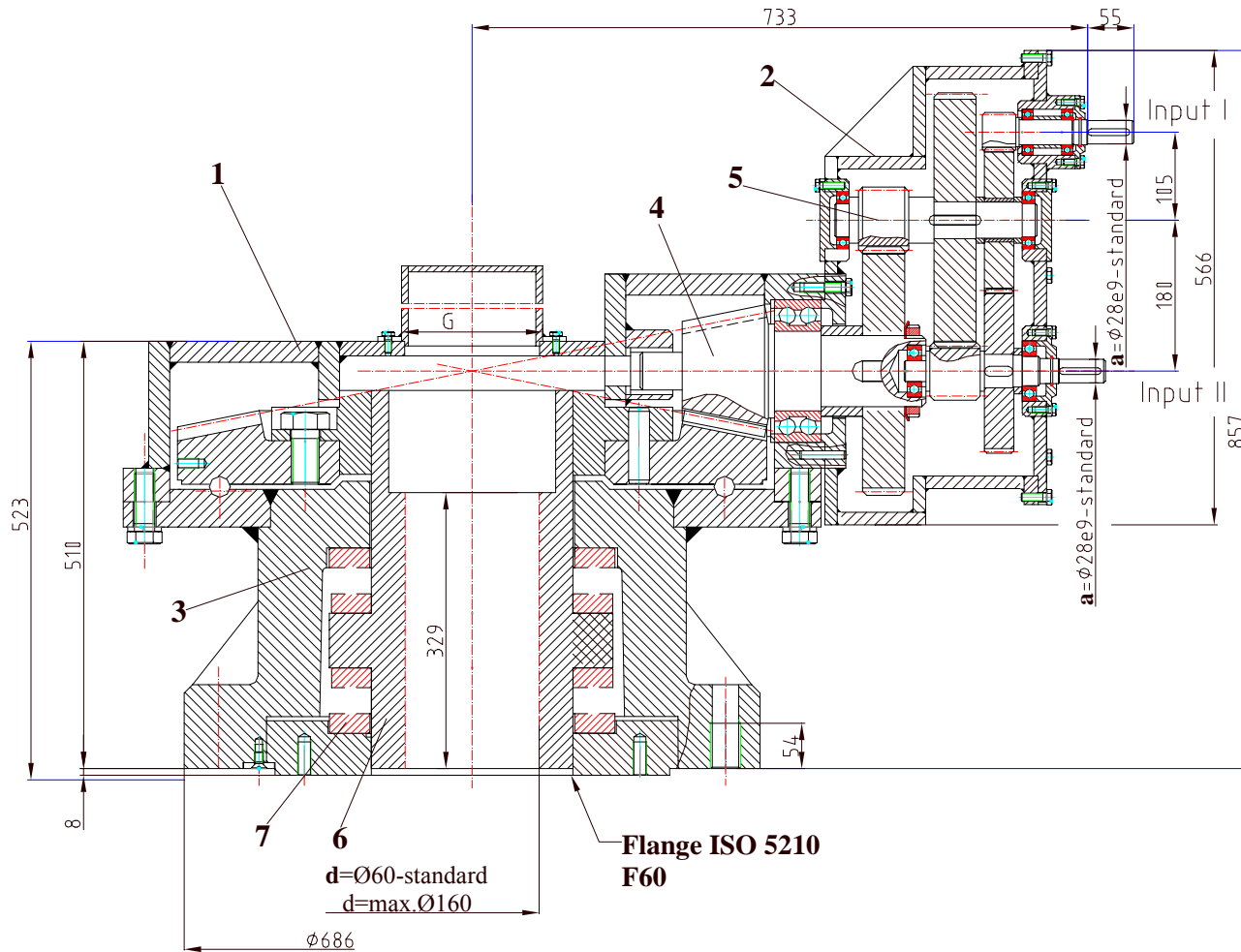

MATERIALS

1. Bevel gear housing:	OL 42/C42
2. Cylindrical gear housing:	OL 42/C42
3. Intermediate:	OL 42/C42
4. Bevel gear:	OL 42/C42
5. Cylindrical gear:	OLC45/C45
6. Driving nut:	Cu Al10Fe 3T Fagn Ni 22
7. Bearing:	81248

TECHNICAL FEATURES

- Ratio: Input I.....493,5
Input II..... 104,6
- Output torque: 50000 Nm
- Axial load: 4500 kN

Input	Ratio	Input torque (Nm)	D (mm)	Handwheel tangential force(N)
I	493,5	195	800	2x487
II	104,6	199		2x497

ORDERING CODE :

2CK 50 x 493,5/104,6 - F60 - OB - 28 - 6'' - 4 / 60 - 2

Type	2 input shafts
Ratio I / Ratio II	d- Coupling shape dimension
Coupling flange ISO 5210	d-Coupling shape code-acc. to NCI-30
OB- Driving nut Bz -standard OF- Driving nut Fagn Ni 22	G-Stem tube thread
	a-Input shaft diameter-key acc. to DIN 6885

Handwheel - A800-standard
A600
Stem tube - A170(6'')
Should be ordered separately!